



VK36W6D Datasheet

6 channel water detection 1 to 1 output

Rev.1.2

Intellectual Property Statement:

Shenzhen Vinka Microelectronics Co., Ltd. (hereinafter referred to as “the Company”) owns legally registered intellectual property rights in both domestic and international jurisdictions. Any unauthorized use of the Company’s products or patented technologies by individuals or organizations is strictly prohibited.

The Company reserves the right to take legal action against any infringement, and to seek full compensation for damages or unlawful gains.

The Company’s name and trademarks are legally protected and may not be used or imitated without explicit written permission. No implied or express license shall be granted under any circumstances.

1 General Description

The VK36W6D has 6 touch detection channels, which can be used to detect the water level at 6 points. This chip has a high degree of integration and can detect touch buttons with only a few external components.

It provides 6-channel output functionality. The chip uses a special integrated circuit inside, which has a high power supply voltage suppression ratio. This can reduce the occurrence of key detection errors. This feature ensures that the chip still has high reliability in adverse environmental conditions.

This touch chip has an automatic calibration function, low standby current, and anti-voltage fluctuation characteristics. It provides a simple and effective implementation method for detecting 6-point water level applications.

2 Key Features

- Operating voltage: 2.2-5.5V
- Standby current 10 μ A/3.0V
- Power-on reset function (POR)
- Low-voltage reset function (LVR)
- 4S Automatic Calibration Function
- Reliable touch button detection
- 4S test detects no water and enters standby mode
- It is possible to conduct a reliable detection even if there is water before powering on.
- 6-point water level measurement
- 1-to-1 direct output
- External capacitors (1nF-47nF) connected to the dedicated pins are used to adjust the sensitivity.
- Very few peripheral components
- Has the function of resisting voltage fluctuations
- The detection can be carried out by using a metal probe to make contact with the water, or it can be done outside the water tank without making contact with the water.
- Available Packages:
 - SOP16(150mil)(9.9mm x 3.9mm PP=1.27mm)
 - QFN16L(3.0mm x 3.0mm PP=0.5mm)

3 Product Selection

Part No.	Voltage/Standby Current	Output	Packaging
VK36W1D	2.2V-5.5V/10 μ A-3V3(SLEEP)	1-to-1 direct output	SOT23-6
VK36W2D	2.2V-5.5V/10 μ A-3V3(SLEEP)	1-to-1 direct output	SOP8
VK36W4D	2.2V-5.5V/10 μ A-3V3(SLEEP)	1-to-1 direct output	SOP16/QFN16L
VK36W6D	2.2V-5.5V/10 μ A-3V3(SLEEP)	1-to-1 direct output	SOP16/QFN16L
VK36W8I	2.2V-5.5V/10 μ A-3V3(SLEEP)	I2C output	SOP16/QFN16L

4 Ordering Information

Part No.	Packaging	Tube Qty	Tray(reel)Qty	Box Qty	Total Qty	Notes
VK36W1D	SOT23-6		3000/reel	30000/box	120000 PCS	
VK36W2D	SOP8	100/tube		10000/box	60000 PCS	
VK36W4D	SOP16	50/tube		5000/box	50000 PCS	
	QFN16L		3000/reel	30000/box	120000 PCS	
VK36W6D	SOP16	50/tube		5000/box	50000 PCS	
	QFN16L		3000/reel	30000/box	120000 PCS	
VK36W8I	SOP16	50/tube		5000/box	50000 PCS	
	QFN16L		3000/reel	30000/box	120000 PCS	

5 Package Pinout Information(SOP16/QFN16L)

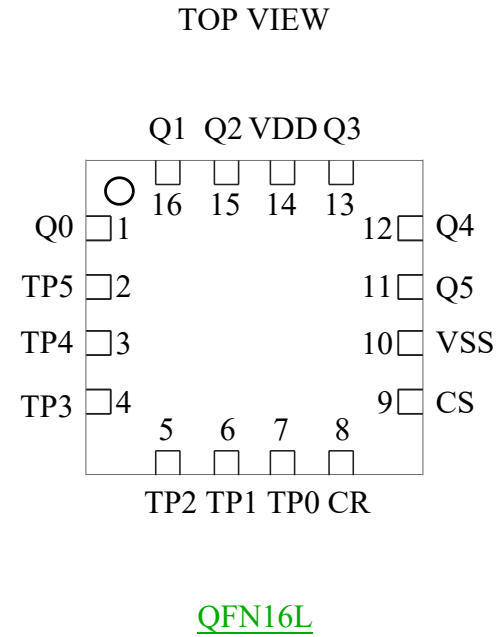
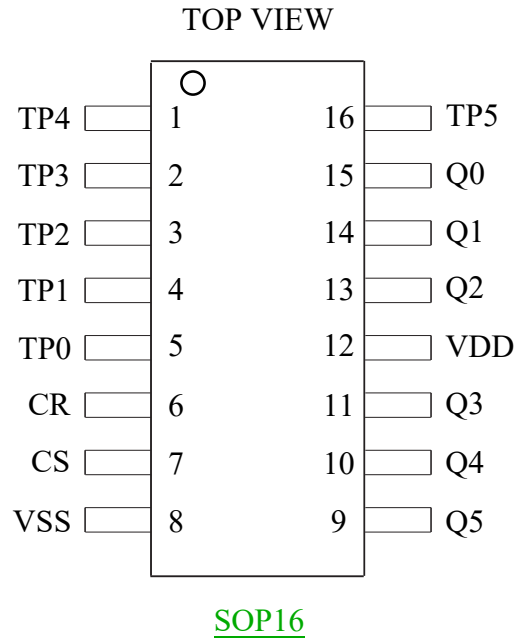

For more information: Page 11-12

5.1 VK36W6D/SOP16/QFN16L Pin Description

Pin Names		I/O	Function Description
SOP16	QFN16L		
1-TP4	3-TP4	I	Touch input, connect to ground with a small capacitor for fine-tuning sensitivity (1-50pF)
2-TP3	4-TP3	I	Touch input, connect to ground with a small capacitor for fine-tuning sensitivity (1-50pF)
3-TP2	5-TP2	I	Touch input, connect to ground with a small capacitor for fine-tuning sensitivity (1-50pF)
4-TP1	6-TP1	I	Touch input, connect to ground with a small capacitor for fine-tuning sensitivity (1-50pF)
5-TP0	7-TP0	I	Touch input, connect to ground with a small capacitor for fine-tuning sensitivity (1-50pF)
6-CR	8-CR	I	Reference capacitor
7-CS	9-CS	I	Sensitivity adjustment, connecting ground capacitor (1-47nF)
8-VSS	10-VSS	VSS	Negative power supply
9-Q5	11-Q5	O	Touch output
10-Q4	12-Q4	O	Touch output
11-Q3	13-Q3	O	Touch output
12-VDD	14-VDD	VDD	Positive power supply
13-Q2	15-Q2	O	Touch output
14-Q1	16-Q1	O	Touch output
15-Q0	11-Q0	O	Touch output
16-TP5	12-TP5	O	Touch input, connect to ground with a small capacitor for fine-tuning sensitivity (1-50pF)

6 Functional Description

6.1 Block Diagram

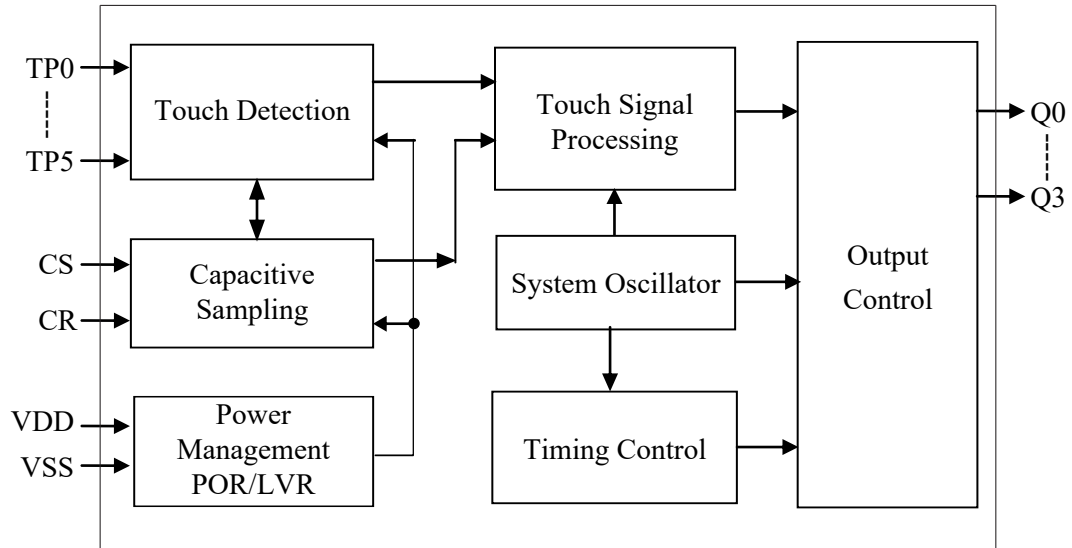

6.2 Automatic Calibration

After power-on, the chip will perform initialization and obtain the first reference value. Subsequently, when there is no touch, the touch chip will automatically calibrate the reference value, enabling the reference value to dynamically change according to the external environment.

For example, this mechanism can achieve reliable touch detection when there is a temperature change or environmental noise.

6.3 Resistance To Voltage Fluctuations

The chip is equipped with an anti-voltage fluctuation function, which can prevent the occurrence of touch button malfunction caused by the sudden drop in working voltage due to the large current driving from the peripheral devices.

6.4 Working Mode

The output of VK36W6D is Q0 to Q5. It has two working modes: standby mode and normal mode.

After power-on, it immediately detects whether there is water or not;

If it detects no water, it automatically enters the standby mode after 4 seconds;

If it detects water, it switches to the normal mode;

If it detects water, the corresponding signal at pin Q is output;

If it detects no water, the corresponding signal at pin Q is also output.

6.5 Sensitivity Adjustment

The sensitivity of VK36W6D is related to the size of the touch pad, the thickness of the casing, the size of the sensitivity capacitor, etc. The sensitivity should be adjusted according to the actual application of the product. The sensitivity can be adjusted from the following aspects:

1. Touch the area of the PAD

Other conditions remaining the same, the larger the touch area, the more sensitive it will be. However, the area must be within the effective range.

2. The thickness of the shell

If all other conditions remain the same, the thinner the casing, the higher the sensitivity; the thicker the casing, the lower the sensitivity. However, the thickness must not exceed the maximum limit.

3. Adjust the capacitance value of the CS terminal to ground

The CS adjusts the overall sensitivity. The higher the value, the more sensitive it is. The common values range from 1 to 47 nF. For some special applications, there are even values exceeding 200 nF.

4. Adjust the ground capacitance value of the CR terminal

Adjust the capacitance value of the CR capacitor. The smaller the value, the more sensitive it is. The common values range from 1 to 10 pF.

5. Adjust the small capacitance between the touch pad and the ground

Adjust the sensitivity of the small capacitance for touching the ground with your foot. The larger the capacitance, the higher the sensitivity. The common value is 1-50pF.

Shell thickness (acrylic or glass)	CS Electrical value (for reference only)
<3mm	6.8nF/25V
3-6mm	10nF/25V
6-10mm	22nF/25V

7 Application Circuits

It is recommended to use LDO for power supply

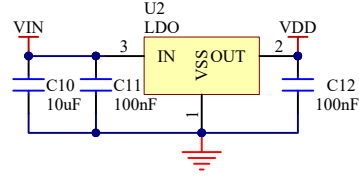

The power supply pin is stabilized by adding a filter capacitor.

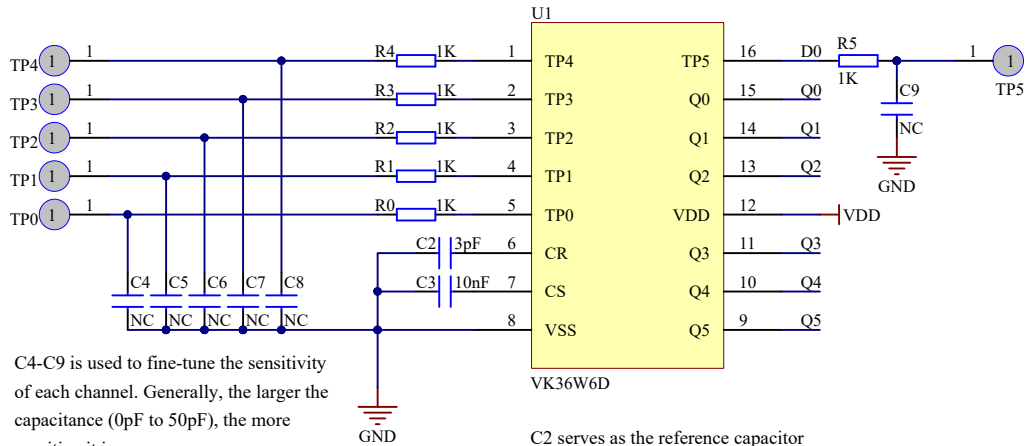
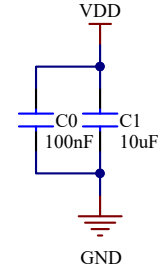

C4-C9 is used to fine-tune the sensitivity of each channel. Generally, the larger the capacitance (0pF to 50pF), the more sensitive it is.

The touch pins are connected in series with a 1K resistor to enhance anti-interference. The resistance value of the 1K resistor is usually in the range of 0R to 10K. Depending on the interference situation, the resistance value can be increased if the interference is severe.

C2 serves as the reference capacitor

C3 is used to adjust the overall sensitivity

Generally, C2 is selected as 10nf and C3 as 3pF, which can meet the application requirements of most products

8 Electrical Characteristics

Absolute Maximum Ratings

Parameter	Symbol	Ratings	Unit
Power Voltage	VDD	-0.3~6.0	V
Input Voltage	V _{IN}	VSS-0.3~VDD+0.3	V
Storage Temperature	T _{STG}	-50~+125	°C
Operating Temperature	T _{OTG}	-40~+85	°C
Human Body Mode	ESD	4KV-8KV(Class 3A)	KV

8.1 DC Electrical Characteristics

Parameter	Symbol	Min.	Typ.	Max.	Unit	Test Conditions (25 °C)	
						VDD	Conditions
Operating voltage	VDD	2.2	3.0	5.5	—	—	—
Low-voltage reset	LVR	—	2.0	2.1	—	—	—
Operating current	I _{OP}	—	1.3	—	mA	3.0V	CS=10nF
		—	2.2	—		5.0V	
Standby current	I _{ST}	—	8	—	μA	3.0V	CS=10nF
		—	33	—		5.0V	
Output sink current	I _{IL}	—	4	—	mA	3.0V	V _{OL} =0.6V
		—	8	—		5.0V	
Output source current	I _{OL}	—	-2	—	mA	3.0V	V _{OH} =2.6V
		—	-4	—		5.0V	V _{OH} =4.3V
Input low voltage	V _{IL}	—	—	0.3	VDD	VDD	Input low voltage
Input high voltage	V _{IH}	0.7	—	1	VDD	VDD	Input high voltage
Q pin pull resistance	R _{PL}	—	60k	—	ohm	3.0V	VDD=3V
Output response time	T _R	—	125	—	mS	3.0V	Normal mode
		—	125	—		5.0V	Normal mode
		—	150	—	mS	3.0V	Standby mode
		—	150	—		5.0V	Standby mode

9 Package Information

9.1 SOP16(9.9mm x 3.9mm PP=1.27mm)

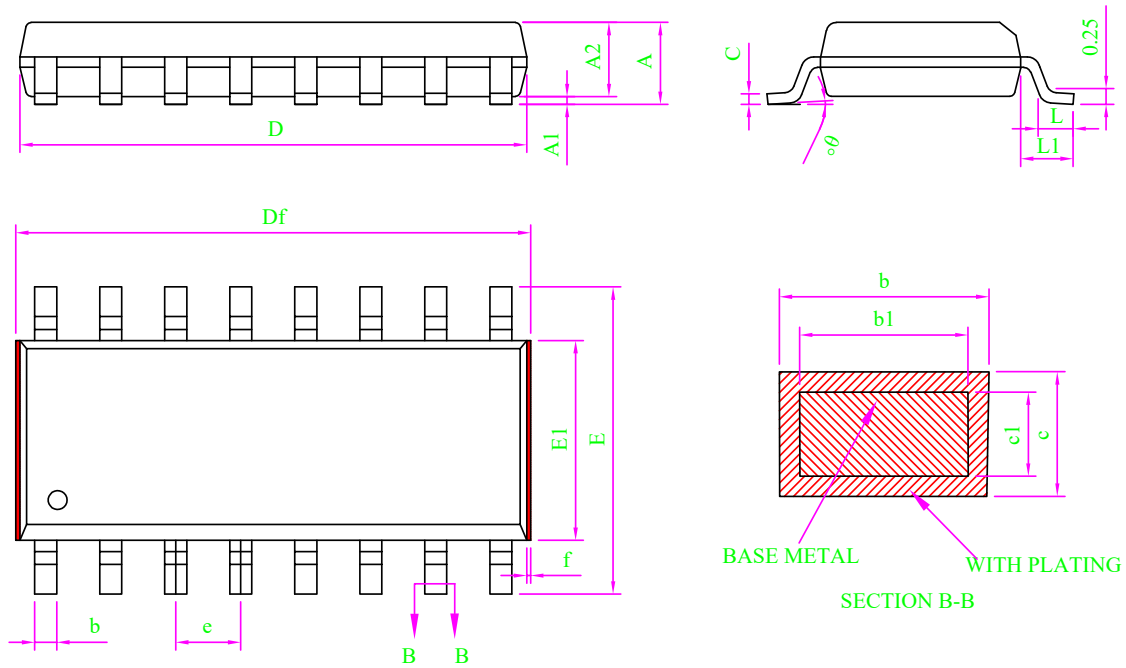

Note:

- All dimension are in mm.
Dim D&E1 does not include plastic flash; Df includes plastic flash(f);
Flash: Plastic residual around body edge after de junk/singulation.
- Dim b does not include dambar protrusion/intrusion.
- Plating thickness 0.007mm-0.020mm

MILLIMETER			
SYMBOL	MIN	NOM	MAX
A	-	-	1.75
A1	0.10	0.15	0.20
A2	1.35	1.45	1.55
b	0.39	-	0.47
b1	0.38	0.41	0.43
c	0.20	-	0.25
c1	0.19	0.20	0.21
D	9.80	9.90	10.00
Df	9.90	-	10.40
E	5.80	6.00	6.20
E1	3.80	3.90	4.00
e	1.27BSC		
L	0.51	0.66	0.81
L1	0.95	1.05	1.15
theta	0	-	8°
f	0.05	-	0.20

9.2 QFN16L(3.0mm x 3.0mm PP=0.5mm)

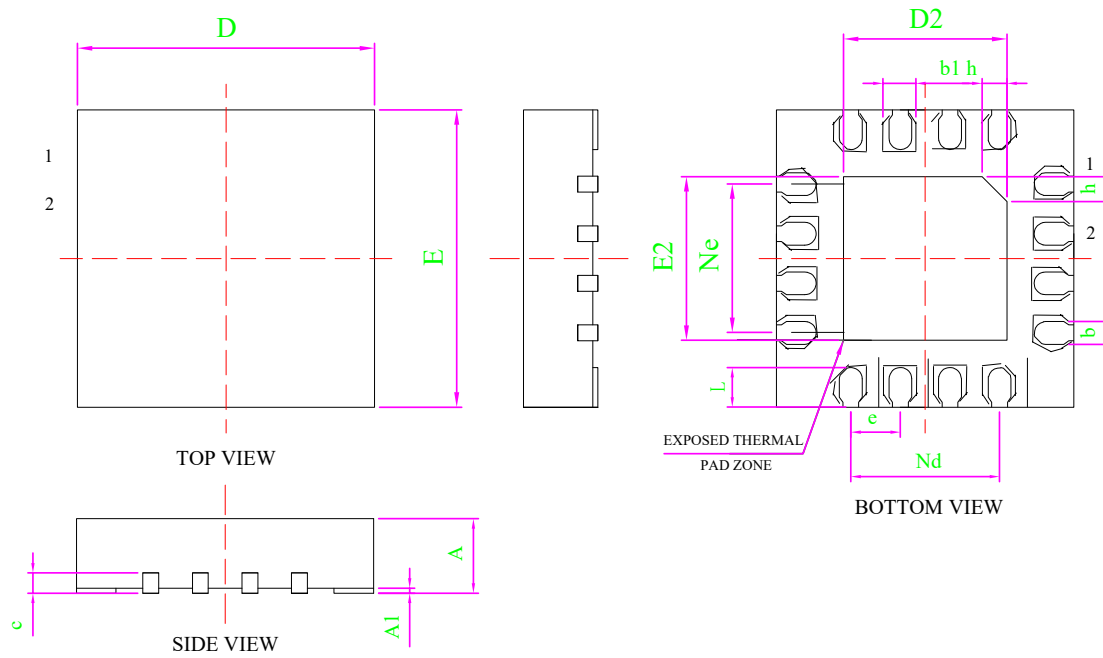

Dimensions			
SYMBOL	MIN	NOMINAL	MAX
A	0.70	0.75	0.80
A1	0	0.02	0.05
b	0.18	0.25	0.30
b1	0.30	0.35	0.40
c	0.18	0.20	0.25
D	2.90	3.00	3.10
D2	1.55	1.65	1.75
e	0.50BSC		
Ne	1.50BSC		
Nd	1.50BSC		
E	2.90	3.00	3.10
E2	1.55	1.65	1.75
L	0.35	0.40	0.45
h	0.20	0.25	0.30
L/F carrier size (mil)	75*75		

10 Disclaimer

Warranty and liability — The information provided in this document is believed to be accurate and reliable. However, Shenzhen Vinka Microelectronics Co., Ltd. (hereinafter “the Company”) makes no warranties, express or implied, as to the completeness or suitability of this information for any specific purpose.

In no event shall the Company be liable for any indirect, incidental, or consequential damages, including but not limited to loss of profits, equipment damage, or system failure, arising out of the use of this product or documentation, regardless of the legal theory under which such liability is asserted.

Right to change — The Company reserves the right to modify any information contained herein without prior notice. The latest version of this document is available at:

<https://www.szvinka.com/>

Applicability — This product is not designed or intended for use in life-critical, medical, or safety systems where failure could result in injury or death. The customer shall assume full responsibility for any such use.

Application — All product application descriptions provided herein are intended for illustrative purposes only.

The Company makes no representations or warranties, express or implied, regarding the suitability of any specific application without further testing or modification.

The customer is solely responsible for determining whether the Company’s products are appropriate for their intended applications or end customers.

The customer shall ensure proper design practices, implementation safeguards, and operational validation to minimize risks associated with product use.

The Company shall not be held liable for any defects, losses, costs, or damages arising from weaknesses or failures in the customer’s own products or applications, or from the integration or use of third-party products.

Furthermore, the customer shall conduct all necessary testing and validation for any third-party deployment of the Company’s products to avoid potential misuse or associated damages. The Company assumes no liability in this regard.

Commercial terms of sale — Unless otherwise agreed in writing, sales of this product are subject to the Company’s standard terms and conditions of sale. The Company expressly rejects the applicability of the customer’s general terms and conditions.

Export control — This product may be subject to applicable export control regulations. The customer is solely responsible for compliance with such regulations, including obtaining any necessary export licenses.

11 Revision History

No.	Version	Date	Modify the content	Check
1	1.0	2018-08-10	Original version	YES
2	1.1	2020-02-11	Add reference circuit	YES
3	1.2	2025-01-29	Update version	YES

[1] Consult the recently published documents before starting or finishing the design.

[2] Since the release of this document , the device product status described in this document may have changed and may differ in several cases. The latest product status information can be found on the Internet at <https://www.szvinka.com/>