



VK36N3D Datasheet

3-channel touch 1-to-1 output

Rev.1.2

Intellectual Property Statement:

Shenzhen Vinka Microelectronics Co., Ltd. (hereinafter referred to as “the Company”) owns legally registered intellectual property rights in both domestic and international jurisdictions. Any unauthorized use of the Company’s products or patented technologies by individuals or organizations is strictly prohibited.

The Company reserves the right to take legal action against any infringement, and to seek full compensation for damages or unlawful gains.

The Company’s name and trademarks are legally protected and may not be used or imitated without explicit written permission. No implied or express license shall be granted under any circumstances.

1 General Description

The VK36N3D has two touch channel, which can be used to detect the touch actions of human hands on the external touch buttons. This chip has a high degree of integration and only requires a few external components to achieve the detection of touch buttons.

It provides 3 1-to-1 output pins. The power-on output level can be selected through the IO pins. There are two types available: direct output and latch output. The chip uses a special integrated circuit, which has a high power supply voltage suppression ratio. This can reduce the occurrence of key detection errors. This feature ensures that the chip maintains high reliability even in adverse environmental conditions.

This touch chip features automatic calibration function, low standby current, and resistance to voltage fluctuations. It provides a simple and effective solution for various applications involving touch keys with 1:1 direct output.

2 Key Features

- Operating voltage: 2.2-5.5V
- Standby current 10 μ A/3.0V
- Power-on reset function (POR)
- Low-voltage reset function (LVR)
- Touch output response time: 48ms in operating mode, 160ms in standby mode
- Select the high or low voltage level of the power output through the AHLB pin.
- Select direct output or latch output through the TOG pin.
- The output consists of 3 1-to-1 output pins and 1 touch status output pin.
- Support multi-key simultaneous touch
- Anti-glitch function, maximum output time of effective key: 13 seconds
- Touchless operation: enters standby mode in 4 seconds
- Adjust overall sensitivity by connecting a ground capacitor to the CS pin (1-47nF)
- Each touch channel is independently connected to a small ground capacitor for fine-tuning sensitivity (0-50pF).
- The system is stable within 0.3 seconds after power-on, and no touching is allowed.
- When there is no touch after power-on, the reference value is automatically calibrated due to environmental changes.
- Resistant to voltage fluctuations and has good anti-interference performance
- Available Packages:
 - SOP16(150mil)(9.9mm x 3.9mm PP=1.27mm)
 - QFN16L(3.0mm x 3.0mm PP=0.5mm)

3 Product Selection

Part No.	Voltage/Standby Current	Output	Packaging
VK36N1D	2.2V-5.5V/10 μ A(3.0V)	Direct/Latch/Open Drain Output	SOT23-6
VK36N2D	2.2V-5.5V/10 μ A(3.0V)	Direct/Latch/Open Drain Output	SOP8
VK36N3D	2.2V-5.5V/10 μ A(3.0V)	Direct/Latch/Open Drain Output	SOP16/QFN16L
VK36N4D	2.2V-5.5V/10 μ A(3.0V)	Direct/Latch/Open Drain Output	SOP16/QFN16L
VK36N5D	2.2V-5.5V/10 μ A(3.0V)	Direct/Latch/Open Drain Output	SOP16/QFN16L
VK36N6D	2.2V-5.5V/10 μ A(3.0V)	Direct/Latch/Open Drain Output	SOP16/QFN16L

4 Ordering Information

Part No.	Packaging	Tube Qty	Tray(reel)Qty	Box Qty	Total Qty	Notes
VK36N1D	SOT23-6		3000/reel	30000/box	120000 PCS	
VK36N2D	SOP8	100/tube		10000/box	100000 PCS	
VK36N3D	SOP16	50/tube		5000/box	50000 PCS	
	QFN16L		3000/reel	30000/box	120000 PCS	
VK36N4D	SOP16	50/tube		5000/box	50000 PCS	
	QFN16L		3000/reel	30000/box	120000 PCS	
VK36N5D	SOP16	50/tube		5000/box	50000 PCS	
	QFN16L		3000/reel	30000/box	120000 PCS	
VK36N6D	SOP16	50/tube		5000/box	50000 PCS	
	QFN16L		3000/reel	30000/box	120000 PCS	

5 Package Pinout Information(SOP16/QFN16L)

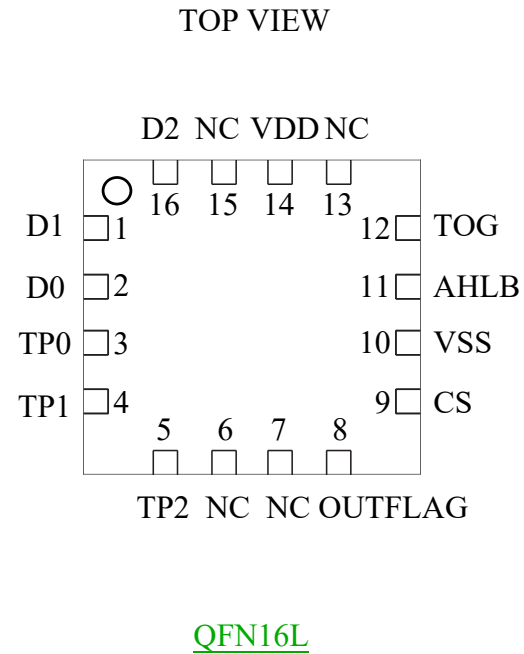
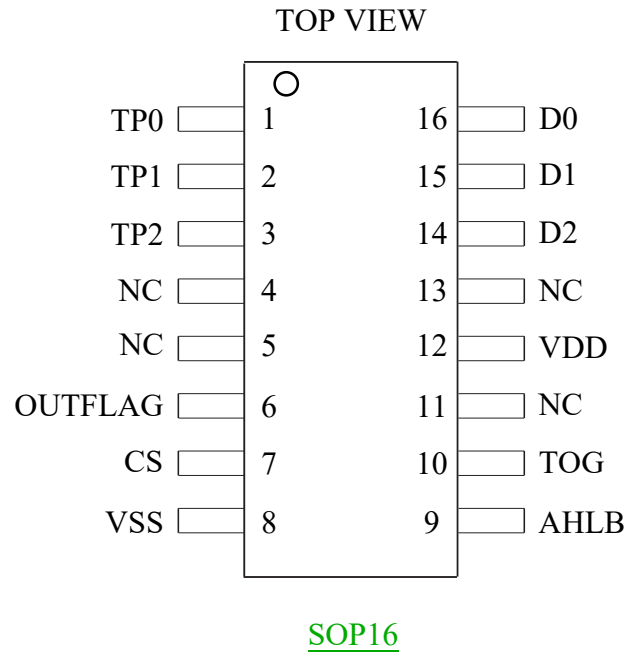

For more information: Page 11-12

5.1 VK36N3D/SOP16/QFN16L Pin Description

Pin Names		I/O	Function Description
SOP16	QFN16L		
1-TP0	3-TP0	I	Touch input. Connect a ground capacitor to fine-tune the sensitivity (1-50pF). No connection results in the highest sensitivity.
2-TP1	4-TP1	I	Touch input. Connect a ground capacitor to fine-tune the sensitivity (1-50pF). No connection results in the highest sensitivity.
3-TP2	5-TP2	I	Touch input. Connect a ground capacitor to fine-tune the sensitivity (1-50pF). No connection results in the highest sensitivity.
4-NC	6-NC	---	---
5-NC	7-NC	---	---
6-OUTFLAG	8-OUTFLAG	O	Touch status output
7-CS	9-CS	I	Sensitivity adjustment, connecting ground capacitor (1-47nF)
8-VSS	10-VSS	VSS	Negative power supply
9-AHLB	11-AHLB	I	Select output level (must not be left floating): VDD > low level is valid, VSS - > high level is valid
10-TOG	12-TOG	I	Select output mode: Suspended -> Direct Output, VSS -> Latched Output
11-NC	13-NC	---	---
12-VDD	14-VDD	VDD	Positive power supply
13-NC	15-NC	---	---
14-D2	16-D2	O	Touch output
15-D1	1-D1	O	Touch output
16-D0	2-D0	O	Touch output

6 Functional Description

6.1 Block Diagram

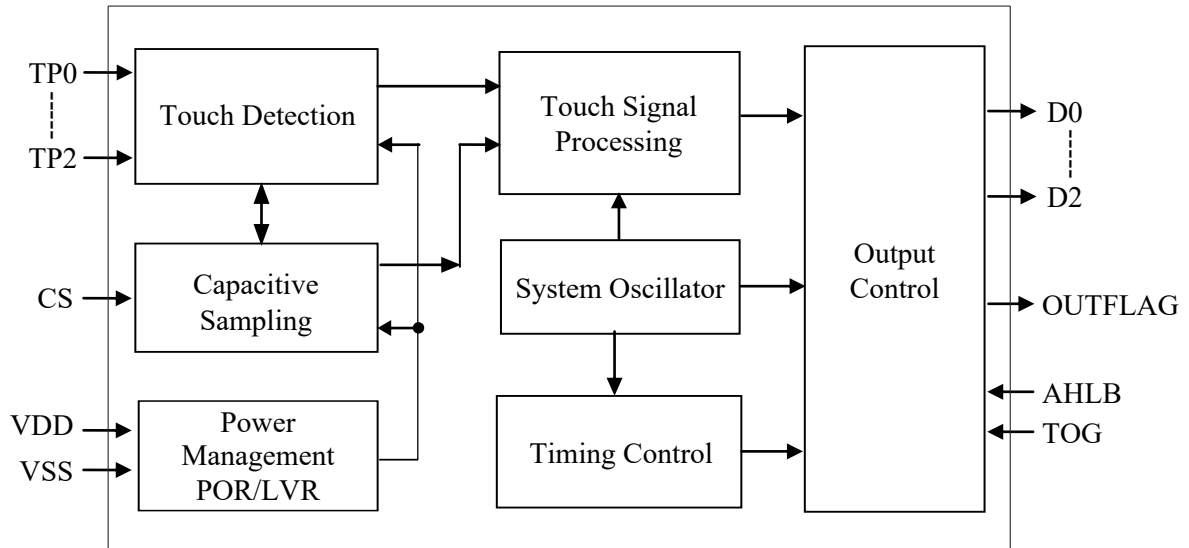

6.2 Auto-calibration Function

After power-on, the chip will perform initialization and obtain the first reference value. Subsequently, when there is no touch, the touch chip will automatically calibrate the reference value, enabling the reference value to dynamically change according to the external environment.

For example, this mechanism can achieve reliable touch detection when there is a temperature change or environmental noise.

6.3 Anti-Calcification Function

To minimize unintended key detection situations such as accidental contact with the sensing pad, a maximum key duration function is set within the chip. When a touch key is pressed, the internal timer starts timing. If the pressing time exceeds approximately 13 seconds, the touch chip will ignore the state of the touched key, recalibrate, obtain a new reference value, and simultaneously reset the status to the initial state upon power-on.

6.4 Resistance To Voltage Fluctuations

The chip is equipped with an anti-voltage fluctuation function, which can prevent the occurrence of touch button malfunction caused by the sudden drop in working voltage due to the large current drive from the peripheral devices.

6.5 Output Mode

The output of VK36N3D is D0 to D2, CMOS output, supporting multiple keys. The valid output level can be selected by the state of the AHLB pin during power-on. The output mode can be selected by the state of the TOG pin during power-on. The OUTFLAG pin outputs the touch status. When there is a change in the touch output level, the output level returns to the power-on state when there is no touch.

AHLB	Select the output of the valid level
VSS	High level is valid. Power-on output is 0.
NC	Low level is valid. Power-on output is 1.

TOG	Select the output method
NC	Direct output
VSS	Latched output

Data format: OUTFLAG + 1: 1 key-value pair.

The AHLB is floating during power-on							
Touch Pin	Output pin		OUTFLAG	Touch Pin	Output pin		OUTFLAG
	TOG=VSS	TOG NC			TOG=VSS	TOG NC	
TP0 Touch	D0=0	D0=0	0	TP0 Release	D0=0	D0=1	1
TP1 Touch	D1=0	D1=0	0	TP1 Release	D1=0	D1=1	1
TP2 Touch	D2=0	D2=0	0	TP2 Release	D2=0	D2=1	1
Note: When powered on, the output level is 1 , OUTFLAG is 1.							

When powered on, AHLB is connected to VSS							
Touch Pin	Output pin		OUTFLAG	Touch Pin	Output pin		OUTFLAG
	TOG=VSS	TOG NC			TOG=VSS	TOG NC	
TP0 Touch	D0=1	D0=1	1	TP0 Release	D0=1	D0=0	0
TP1 Touch	D1=1	D1=1	1	TP1 Release	D1=1	D1=0	0
TP2 Touch	D2=1	D2=1	1	TP2 Release	D2=1	D2=0	0
Note: When powered on, the output level is 0 , OUTFLAG is 0.							

6.6 Operating Mode

The VK36N3D chip has two operating modes: standby mode and normal mode. Press the key to switch to the normal mode. When no key is touched, the 4S automatically enters the standby mode to reduce power consumption. When $VDD = 5V$, the output response of D4-D0 in the standby mode is approximately 160 milliseconds, while in the operating mode it is approximately 48 milliseconds.

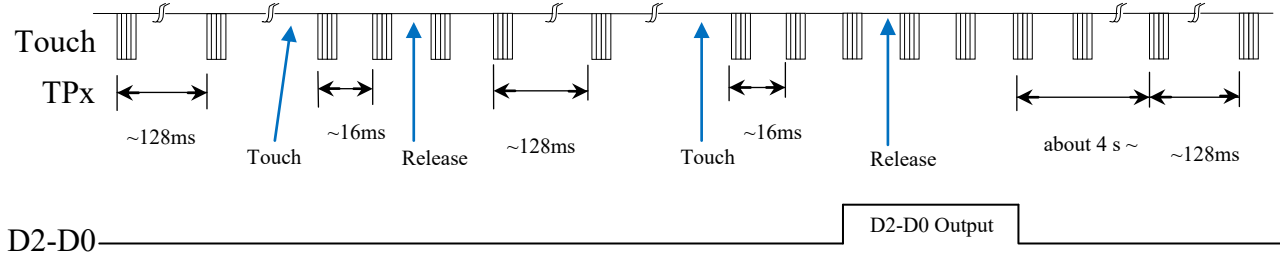

6.7 Sensitivity Adjustment

The sensitivity of VK36N3D is related to the size of the touch PAD, the thickness of the shell, the size of the sensitivity capacitance, etc. The sensitivity should be adjusted according to the actual application of the product. The sensitivity can be adjusted from the following four aspects:

1. Touch the area of the PAD
Under other unchanged conditions, the larger the touch area, the more sensitive it is, but the area must be within the effective area.
2. The thickness of the shell
Under other unchanged conditions, the thinner the casing, the higher the sensitivity; the thicker the casing, the lower the sensitivity. However, the thickness must not exceed the maximum limit.
3. Adjust the capacitance value of pin CS to ground
CS adjusts the overall sensitivity. The larger the value, the more sensitive it is. Commonly used values range from 1 to 47nF, and for some special applications, there are also values exceeding 200nF.
4. Adjust the small capacitance between the touch foot and the ground
The sensitivity is fine-tuned by touching the small capacitance of the touch foot to the ground. The larger the capacitance, the lower the sensitivity. It is most sensitive without a capacitor. Common values range from 1 to 50pF.

Shell thickness (acrylic or glass)	CS Electrical value (for reference only)
<3mm	6.8nF/25V
3-6mm	10nF/25V
6-10mm	22nF/25V

7 Application Circuits

It is recommended to use LDO for power supply

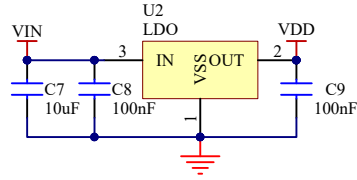

The power supply pin is stabilized by adding a filter capacitor.

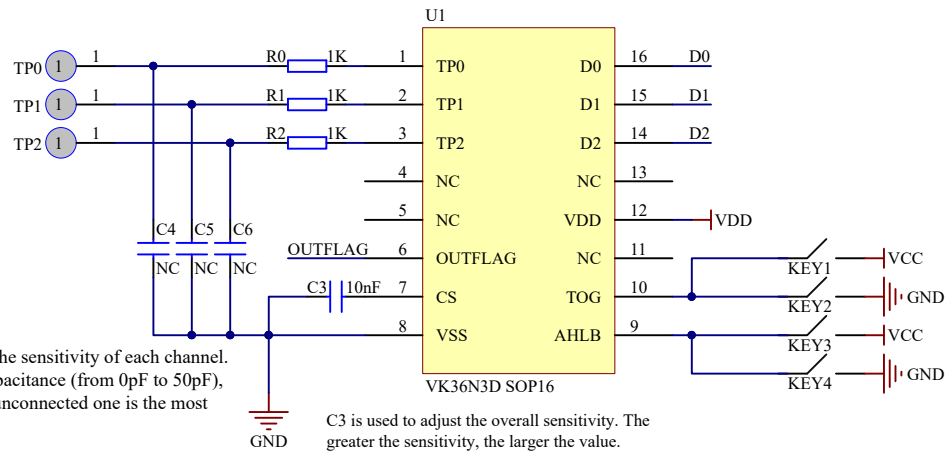
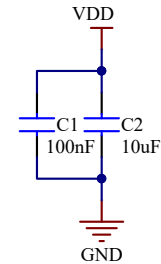

C4-C6 is used to fine-tune the sensitivity of each channel. Generally, the larger the capacitance (from 0pF to 50pF), the less sensitive it is. The unconnected one is the most sensitive.

The touch pins are connected in series with a 1K resistor to enhance anti-interference. The resistance value of the series-connected 1K resistor usually ranges from 0R to 10K. Depending on the interference situation, the resistance value should be increased if the interference is severe.

C3 is used to adjust the overall sensitivity. The greater the sensitivity, the larger the value. Generally, it ranges from 1 nF to 47 nF.

AHLB

VDD Low level is valid. Power-on output is 1.
GND High level is valid. Power-on output is 0.

TOG

VDD Direct output
GND Latched output

8 Electrical Characteristics

Absolute Maximum Ratings

Parameter	Symbol	Ratings	Unit
Power Voltage	VDD	-0.3~6.0	V
Input Voltage	V _{IN}	GND-0.3~VDD+0.3	V
Storage Temperature	T _{STG}	-50~+125	°C
Operating Temperature	T _{OTG}	-40~+85	°C
Human Body Mode	ESD	4KV-8KV(Class 3A)	KV

8.1 DC Electrical Characteristics

Parameter	Symbol	Min.	Typ.	Max.	Unit	Test Conditions (25 °C)	
						VDD	Conditions
Operating voltage	VDD	2.2	3.0	5.5	—	—	—
Low-voltage reset	LVR	—	2.0	2.1	—	—	—
Operating current	I _{OP}	—	1.3	—	mA	3.0V	CS=10nF
		—	2.2	—		5.0V	
Standby current	I _{ST}	—	10	—	μA	3.0V	CS=10nF
		—	33	—		5.0V	
Output sink current	I _{IL}	—	4	—	mA	3.0V	V _{OL} =0.6V
		—	8	—		5.0V	
Output source current	I _{OL}	—	-2	—	mA	3.0V	V _{OH} =2.6V
		—	-4	—		5.0V	V _{OH} =4.3V
Input low voltage	V _{IL}	—	—	0.3	VDD	VDD	Input low voltage
Input high voltage	V _{IH}	0.7	—	1	VDD	VDD	Input high voltage
Input the pull-up resistor	R _{PH}	—	150k	—	ohm	3.0V	VDD=3V
Input the pull-down resistor	R _{PL}	—	50k	—	ohm	3.0V	VDD=3V
Output response time	T _R	—	45	—	mS	3.0V	Operating mode
		—	48	—		5.0V	Operating mode
		—	150	—	mS	3.0V	Standby mode
		—	160	—		5.0V	Standby mode

9 Package Information

9.1 SOP16(9.9mm x 3.9mm PP=1.27mm)

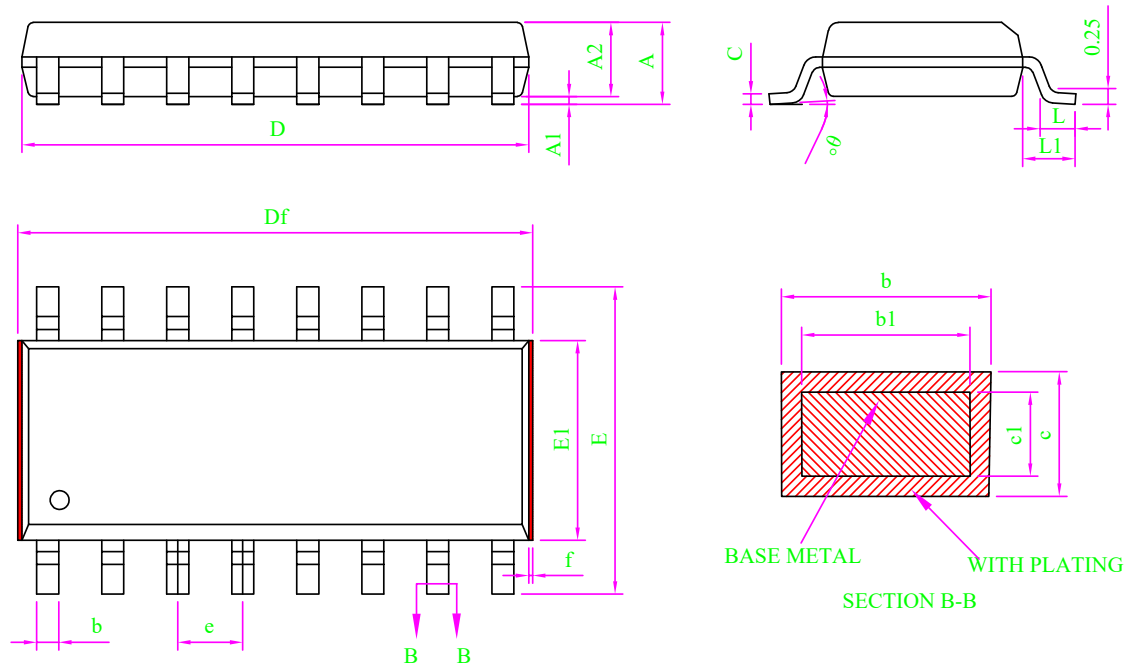

Note:

- All dimension are in mm.
Dim D&E1 does not include plastic flash; Df includes plastic flash(f);
Flash: Plastic residual around body edge after de junk/singulation.
- Dim b does not include dambar protrusion/intrusion.
- Plating thickness 0.007mm-0.020mm

MILLIMETER			
SYMBOL	MIN	NOM	MAX
A	-	-	1.75
A1	0.10	0.15	0.20
A2	1.35	1.45	1.55
b	0.39	-	0.47
b1	0.38	0.41	0.43
c	0.20	-	0.25
c1	0.19	0.20	0.21
D	9.80	9.90	10.00
Df	9.90	-	10.40
E	5.80	6.00	6.20
E1	3.80	3.90	4.00
e	1.27BSC		
L	0.51	0.66	0.81
L1	0.95	1.05	1.15
θ	0	-	8°
f	0.05	-	0.20

9.2 QFN16L(3.0mm x 3.0mm PP=0.5mm)

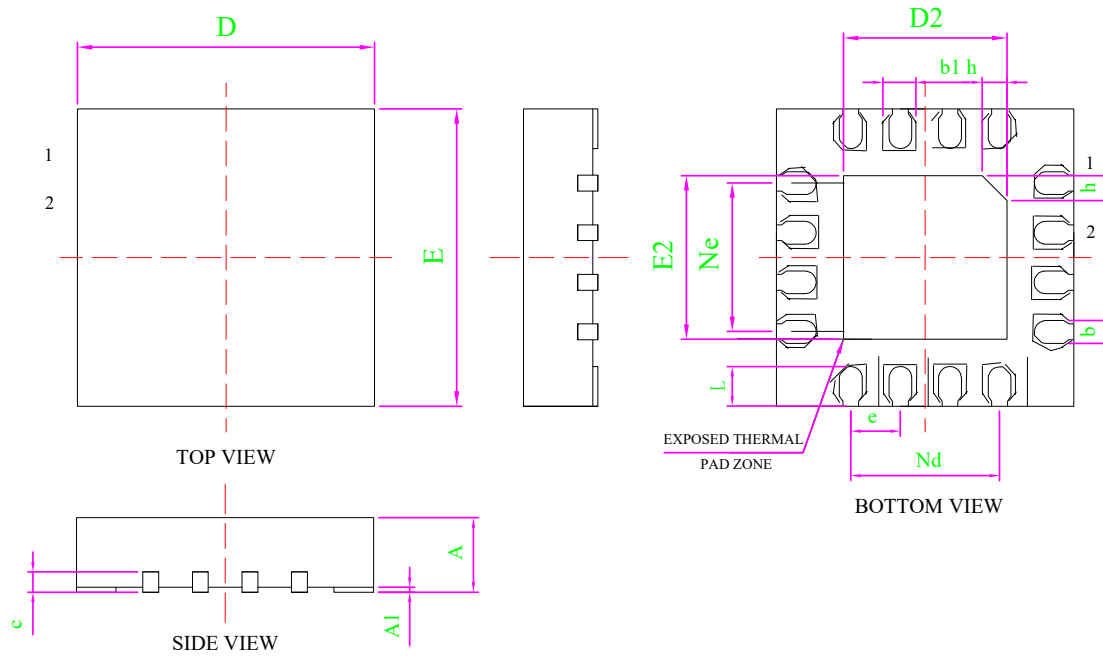

Dimensions			
SYMBOL	MIN	NOMINAL	MAX
A	0.70	0.75	0.80
A1	0	0.02	0.05
b	0.18	0.25	0.30
b1	0.30	0.35	0.40
c	0.18	0.20	0.25
D	2.90	3.00	3.10
D2	1.55	1.65	1.75
e	0.50BSC		
Ne	1.50BSC		
Nd	1.50BSC		
E	2.90	3.00	3.10
E2	1.55	1.65	1.75
L	0.35	0.40	0.45
h	0.20	0.25	0.30
L/F Carrier size (miL)	75*75		

10 Disclaimer

Warranty and liability — The information provided in this document is believed to be accurate and reliable. However, Shenzhen Vinka Microelectronics Co., Ltd. (hereinafter “the Company”) makes no warranties, express or implied, as to the completeness or suitability of this information for any specific purpose.

In no event shall the Company be liable for any indirect, incidental, or consequential damages, including but not limited to loss of profits, equipment damage, or system failure, arising out of the use of this product or documentation, regardless of the legal theory under which such liability is asserted.

Right to change — The Company reserves the right to modify any information contained herein without prior notice. The latest version of this document is available at:

<https://www.szvinka.com/>

Applicability — This product is not designed or intended for use in life-critical, medical, or safety systems where failure could result in injury or death. The customer shall assume full responsibility for any such use.

Application — All product application descriptions provided herein are intended for illustrative purposes only. The Company makes no representations or warranties, express or implied, regarding the suitability of any specific application without further testing or modification.

The customer is solely responsible for determining whether the Company’s products are appropriate for their intended applications or end customers.

The customer shall ensure proper design practices, implementation safeguards, and operational validation to minimize risks associated with product use.

The Company shall not be held liable for any defects, losses, costs, or damages arising from weaknesses or failures in the customer’s own products or applications, or from the integration or use of third-party products.

Furthermore, the customer shall conduct all necessary testing and validation for any third-party deployment of the Company’s products to avoid potential misuse or associated damages. The Company assumes no liability in this regard.

Commercial terms of sale — Unless otherwise agreed in writing, sales of this product are subject to the Company’s standard terms and conditions of sale. The Company expressly rejects the applicability of the customer’s general terms and conditions.

Export control — This product may be subject to applicable export control regulations. The customer is solely responsible for compliance with such regulations, including obtaining any necessary export licenses.

11 Revision History

No.	Version	Date	Modify the content	Check
1	1.0	2018-08-10	Original version	YES
2	1.1	2020-02-11	Add reference circuit	YES
3	1.2	2026-01-12	Update version	YES

[1] Consult the recently published documents before starting or finishing the design.

[2] Since the release of this document , the device product status described in this document may have changed and may differ in several cases. The latest product status information can be found on the Internet at <https://www.szvinka.com/>